

**DOCUMENTS REQUIRED TO MAKE APPLICATION FOR A MOBILE HOME PERMIT  
DUE TO TIME INVOLVED TO PROCESS PAPERWORK**

**NO APPLICATION OR PERMIT WILL BE PROCESSED AFTER 4:30 P.M.**

1. **Application completed. Incomplete applications will be rejected.**
2. Parcel description of property (**property card**) from Property Appraiser's Office or at [www.suwanneepa.com](http://www.suwanneepa.com). **If property card is in the name of the previous owner, then you MUST provide a copy of the recorded deed proving your ownership of the property, OR (2) have a consent form signed by the previous owner.**
3. **Survey** of property prepared by a land surveyor or engineer registered in Florida. All property stakes shall be in place at the time of application. If a survey is **not** available and it's not in a subdivision you can request an exemption letter from the Zoning Department via email at [ronaldrm@suwcountyfl.gov](mailto:ronaldrm@suwcountyfl.gov).
4. If your property is **LESS** than **5 acres**, **NOT** in a recorded subdivision, **NOT** in a residential zoning district then you will need a deed showing that property was a lot of record prior to **September 9, 1991**.
5. **Site plan** showing **location of residence, driveway and distance to side property line, septic tank and well and distance from the front, sides and rear of property.** (A-1 district must meet minimum setback requirements of 30 ft. from front property line {any property line fronting a roadway} and 15 ft. from sides and rear property lines.)
6. Must provide a copy of **current tag registration (number or title is not sufficient), OR sales contract** for mobile home if purchasing from dealer. **In accordance with Technical Advisory from the Division of Motor Vehicles - "Wind Zone I mobile homes cannot be placed or resited anywhere in the State of Florida". It is your responsibility to verify this information before purchasing a mobile home. If manufactured in Florida have VIN # and call 850-617-2808, if manufactured in Georgia 404-656-3205.**
7. **Must provide letter or other documentation from electric service provider confirming they service the property.**
8. Completed 911 addressing application (attached).
9. **Installation paperwork, completed by a licensed installer, and returned to Building Department.**
10. Completed owner disclosures if work is being conducted by the **property owners**.
11. **Application process for a new septic tank permit or approval letter for an existing septic tank with Environmental Health (386-362-2708 Ext. 243), must be started BEFORE submitting your building permit application to the building department. These documents must be received from Environmental Health before a building permit will be issued.**
12. **If it is determined that your parcel lies in a flood prone area a survey by a land surveyor or engineer registered in Florida will be required. NOTE!!! If your property is located in the floodway of the SFHA, you will be required to obtain both an Environmental Resource Permit (ERP) from the Suwannee River Water Management District and a Zero Rise Certification from a Registered Professional Engineer before an application can be processed. If your property is in a special flood hazard area (SFHA), according to the Federal Emergency Management Agency (FEMA) Flood Insurance Rate Maps (FIRM), an Elevation Certificate (EC) prepared by a Registered Surveyor or Professional Engineer certifying that the bottom of the lowest horizontal structural member of the lowest floor is at least one foot above the base flood elevation is required prior to a final inspection. The ERP will also be required if your property fronts the river, even if the building site is located out of the floodway.**
13. If mobile home is to be occupied by someone other than the property owner, additional information may be needed.
14. Driveway Application to be completed at the time the permit is issued. **Driveways must be inspected if it has not been inspected within the last year.**
14. You **SHOULD** go over checklist **PRIOR** to calling for final inspection; failure to do so may result in a reinspection fee of \$35.00. **DUE TO POSSIBLE DUPLICATION OF NAME AND TIME INVOLVED IN LOOKING FOR PERMIT NUMBER. YOU MUST PROVIDE OFFICE PERSONNEL WITH PERMIT NUMBER WHEN CALLING FOR INSPECTION.**
15. A change of mind after securing permit will result in an additional charge of \$25.00 administrative costs for reprocessing paperwork.

**BUILDING PERMIT FEE \$325.00    COUNTY DRIVEWAY PERMIT FEE \$50.00    911 ADDRESS FEE \$30.00**

**Pro-rata share of assessment for solid waste and fire service MUST be paid for the balance of the year. See chart inside packet.**

**THESE INSTRUCTIONS ARE FOR THE IDEAL CASE, DEPENDING ON INDIVIDUAL NEED CIRCUMSTANCES MAY VARY.**

# HOW TO APPLY FOR A PERMIT

## THESE STEPS ARE FOR PROPERTY NOT LOCATED IN THE FLOODWAY OR FLOODPLAIN.

1. Secure application packet from Building Department.
2. Return completed forms and required documentation listed on cover page to the Building Department. (Including driveway application, 911 addressing form)
3. After Zoning Compliance Approval is granted, the Building Department will send the approval to the Environmental Health Department. **You must apply for a septic permit before your building permit is issued.**
4. The Building Department will submit the 911 addressing form and driveway application to the appropriate departments.
5. Complete improvements and call Building Department for inspection (**permit number and 24-hr notice required**) at 386-364-3407 between the hours of 8:00 a.m. and 4:30 p.m., Monday through Friday.
6. Provided improvements pass inspection, final approval of driveway is received from Public Works Department, the fire and solid waste tax assessment is paid, final approval on septic is received from Environmental Health Department, the Power Company, as provided by you, will be notified to release power to dwelling.

**TWENTY-FOUR HOUR ADVANCED NOTICE AND PERMIT NUMBER  
REQUIRED FOR INSPECTION, HOWEVER, NEXT DAY INSPECTION IS NOT GURANTEED.**

**NOTE: THERE WILL BE A \$35.00 REINSPECTION FEE CHARGED IF THE SCHEDULED INSPECTION IS NOT READY AT THE REQUESTED TIME. SUBSEQUENT REINPSECTION FEES WILL BE \$50.00 FOR ADDITIONAL INSPECTIONS.**

# MOBILE HOME PERMIT APPLICATION

SUWANNEE COUNTY BUILDING DEPARTMENT

224 PINE AVENUE, LIVE OAK FL 32064

(P) 386-364-3407 • (F) 386-364-3754 • [scpermit.com](http://scpermit.com) • [permits@suwcountyfl.gov](mailto:permits@suwcountyfl.gov)

APPLICANT: \_\_\_\_\_ PHONE NO. \_\_\_\_\_

CURRENT ADDRESS \_\_\_\_\_

PROPERTY OWNER NAME: \_\_\_\_\_

ADDRESS: \_\_\_\_\_

CONTACT EMAIL: \_\_\_\_\_

LEGAL DESCRIPTION: (as found on the parcel description printout)

Sec. \_\_\_\_\_ Twp. \_\_\_\_\_ S Rge. \_\_\_\_\_ E Tax Parcel No. \_\_\_\_\_

Lot \_\_\_\_\_ Subdivision \_\_\_\_\_

Size \_\_\_\_\_ Acres Number of Other Dwellings: \_\_\_\_\_

HOW DO YOU GET THERE FROM THIS OFFICE: **You MUST give road numbers and EXACT directions**

Electrical Contractor \_\_\_\_\_ License # \_\_\_\_\_

Mechanical Contractor \_\_\_\_\_ License # \_\_\_\_\_

Mobile Home Year/Make: \_\_\_\_\_ Size: \_\_\_\_\_

TAG DECAL # \_\_\_\_\_ DEALER: \_\_\_\_\_

INSTALLER: \_\_\_\_\_ LICENSE # \_\_\_\_\_ Mobile #: \_\_\_\_\_

POWER COMPANY: SVEC: \_\_\_\_\_ **NEW RESIDENCE?** YES: \_\_\_\_\_ NO: \_\_\_\_\_

FP&L: \_\_\_\_\_

DUKE: \_\_\_\_\_

Application is hereby made to obtain a permit to do the work and installations as indicated. I certify that no work or installation has commenced prior to the issuance of a permit and that all work will be performed to meet the standards of all laws regulating construction and zoning in Suwannee County. **I understand that I MUST supply the office personnel with the permit number when calling for inspections.** (If mobile home dealer/agent – I understand it is my responsibility to make the customer aware of procedures.) **I certify that the entire foregoing information and site plan is accurate and have fully read the entire application package and understand its content.**

DATE: \_\_\_\_\_

\_\_\_\_\_  
Signature of Applicant/Agent/Property Owner

**THIS APPLICATION WILL EXPIRE IN 90 DAYS UNLESS A PERMIT IS ISSUED.**

## MOBILE HOME CHECKLIST

The following is a quick checklist of items that **MUST** be observed **PRIOR** to calling for a final inspection on a mobile home permit. You **MUST** provide office personnel with **permit number** when calling for inspection.

- \_\_\_ All New Mobile Homes require a pad inspection prior to placing mobile home on property
- \_\_\_ Place yellow copy of permit in window of mobile home facing roadway that is closest to driveway. **When you are ready for inspection** - attach yellow copy of permit to power pole.
- \_\_\_ Mobile home **MUST** be **UNLOCKED**. (**If locked you will automatically fail inspection and be charged a \$35.00 reinspection fee**).
- \_\_\_ A set of steps at any door, if over 30" must have handrails & 36" platform area.
- \_\_\_ Porches require a separate permit.
- \_\_\_ Well installed, all water and electrical lines completed and left uncovered.
- \_\_\_ Septic tank installed, covered and inspected by Health Department. **Final Inspection** report must be supplied before power can be released to the power company. It is your responsibility to call them for a final inspection at 386-339-6091.
- \_\_\_ Power pole installed, and all electric hooked up (including air conditioning). Two ground rods 6 feet or more apart is required. If air conditioning unit is not connected at time of final inspection a separate permit must be obtained before installation.
- \_\_\_ HVAC ductwork is unconditioned space must be minimum R-8.0
- \_\_\_ **ALL** ditches open for inspection. Must not mix black (ABS) and white (PVC) pipe for drain lines, may use only **one** transition fitting with proper glue or mechanical joint.
- \_\_\_ Neutral and ground connected **PROPERLY** inside mobile home electric main panel. Leave cover off all electric panels for inspection. As a word of caution, Inspectors suggest that **customer** check all electric connections to make sure they are secured properly before power is supplied to mobile home.
- \_\_\_ 4" sewer line sealed at septic tank and left uncovered with a cleanout 3 feet from home.
- \_\_\_ Just below the point of entry into mobile home a cutoff valve and hose connection faucet with back flow prevention **must** be installed. Hose connection faucet should be **below** cutoff to retain water pressure on hose after valve is shut off.
- \_\_\_ Home blocked and anchored by approved method.
- \_\_\_ Driveway **approved** by Public Works Department call 386-362-3992.
- \_\_\_ Installer's **dated** state setup sticker on mobile home prior to inspection.
- \_\_\_ **DO NOT** install skirting prior to inspection.
- \_\_\_ If in flood prone area - you **MUST** furnish this department with a Original Elevation Certificate of the "finished floor elevation" by a **Florida Registered Surveyor** before scheduling your inspection.
- \_\_\_ 911 address numbers **MUST** be displayed at driveway entrance (see insert in packet) if more than one residence using the same driveway post 911 numbers at entrance of driveway and at residence.

**If ANY of the above items are not complete upon inspection, a \$35.00 reinspection fee will be charged as well as cause an unnecessary delay of your power hook-up.**

**Any further questions, please contact the Building Department at 386-364-3407**

I UNDERSTAND THAT ACCURATE MEASUREMENTS AND NORTH, SOUTH, EAST, WEST DIRECTIONS ARE INTEGRAL PARTS OF MY SITE PLAN WHICH WILL BE USED TO DETERMINE SETBACKS FOR ZONING COMPLIANCE. I ALSO UNDERSTAND THAT IF INSUFFICIENT OR INCORRECT INFORMATION IS SUPPLIED IT WILL CREATE A DELAY IN THE ISSUANCE OF A BUILDING PERMIT.

JOHN DOE

**EXAMPLE SITE PLAN FORM**  
**SUWANNEE COUNTY BUILDING DEPARTMENT**

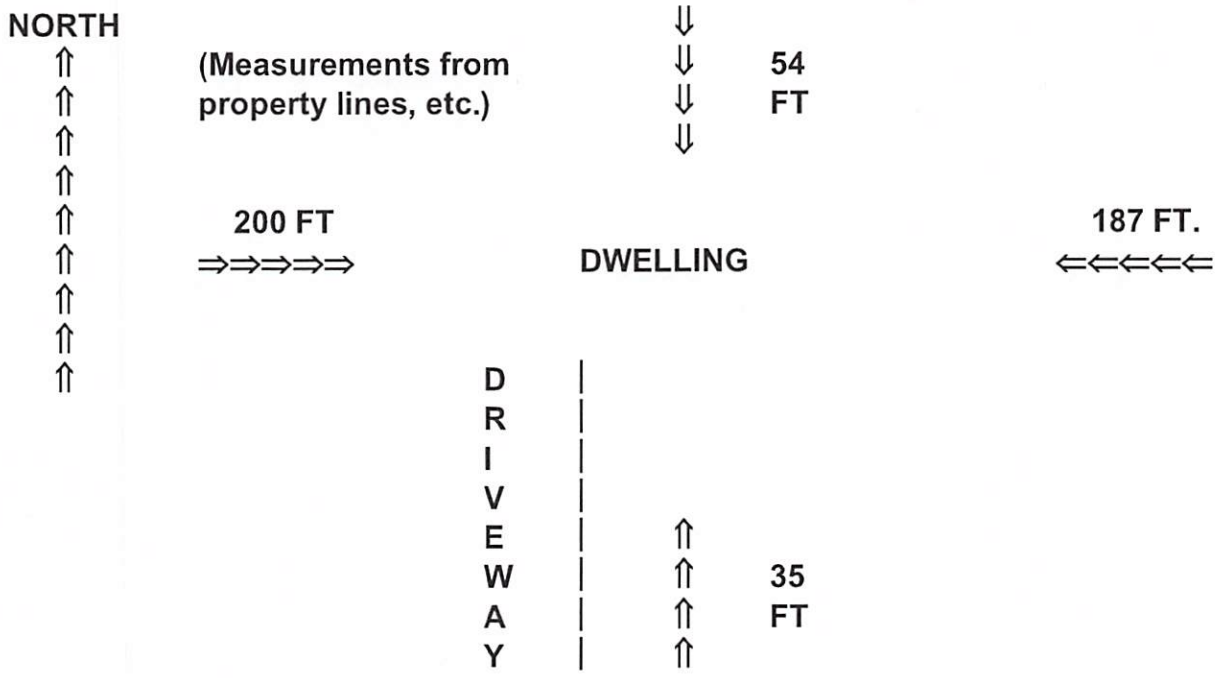

---

Name of Road

---

**ITEMS THAT MUST BE ON THE FORM**

- 1) SHOW ROAD NAME & DRIVEWAY ENTRANCE
- 2) ALL RESIDENCES, BARNS, & ALL OTHER BUILDINGS & SHEDS
- 3) DRIVEWAYS & ENTRANCEWAYS - **SHOWING DISTANCE TO SIDE PROPERTY LINE**
- 4) MEASUREMENTS FROM ALL STRUCTURES & POWER POLE FROM PROPERTY LINE
- 5) MUST HAVE NORTH, SOUTH, EAST & WEST LOCATION ON PLAN
- 6) SITE PLAN MUST BE COMPLETED, SIGNED & DATED **PRIOR** TO BRINGING IT BACK TO THE OFFICE.
- 7) **ALL DWELLINGS ON SAID PARCEL MUST BE SHOWN ON SITE PLAN – AND DISTANCE BETWEEN EACH DWELLING INDICATED.**

PLAN DRAWN BY:

JOHN DOE  
SIGNATURE

01/01/00  
DATE

I UNDERSTAND THAT ACCURATE MEASUREMENTS AND NORTH, SOUTH, EAST, WEST DIRECTIONS ARE INTEGRAL PARTS OF MY SITE PLAN WHICH WILL BE USED TO DETERMINE SETBACKS FOR ZONING COMPLIANCE. I ALSO UNDERSTAND THAT IF INSUFFICIENT OR INCORRECT INFORMATION IS SUPPLIED IT WILL CREATE A DELAY IN THE ISSUANCE OF A BUILDING PERMIT.

SITE PLAN FORM  
SUWANNEE COUNTY BUILDING DEPARTMENT

NORTH



**Do Site Plan on survey or GIS map  
obtain from Property Appraiser Website.  
[www.suwaneepea.com](http://www.suwaneepea.com)**

Identify access roadway to dwelling.

ITEMS THAT MUST BE ON THE FORM

- 1) STREET & ROAD NUMBERS (EXAMPLE - 56TH STREET)
- 2) ALL RESIDENCES, BARNs, & ALL OTHER BUILDINGS & SHEDS
- 3) DRIVEWAYS & ENTRANCEWAYS TO PROPERTY
- 4) MEASUREMENTS FROM ALL STRUCTURES & POWER POLE FROM PROPERTY LINE
- 5) MUST HAVE NORTH, SOUTH, EAST & WEST LOCATION ON PLAN
- 6) SITE PLAN MUST BE COMPLETED, SIGNED & DATED **PRIOR** TO BRINGING IT BACK TO THE OFFICE.
- 7) **ALL DWELLINGS ON SAID PARCEL MUST BE SHOWN ON SITE PLAN – AND DISTANCE BETWEEN EACH DWELLING INDICATED.**

PLAN DRAWN BY:

\_\_\_\_\_  
SIGNATURE

SUWANNEE COUNTY

\_\_\_\_\_  
DATE

# E-911 NEW ADDRESS NUMBER REQUEST

APPLICANT: \_\_\_\_\_

PERMIT #: \_\_\_\_\_

Beginning June 6, 2001, there will be a \$30.00 charge for assignment of a new 911 Address (instituted by the Board of County Commissioners, Suwannee County on 6/5/01).

I UNDERSTAND THAT A REQUIREMENT OF MY OBTAINING A 911 ADDRESS IS DEPENDENT UPON MY COMPLETE COMPLIANCE WITH THE FOLLOWING INSTRUCTIONS:

1. I will be required to denote the four (4) corners of the proposed structure with distance to property lines and show the entrance of the driveway including the road name that you will enter from on the site plan submitted to the Building Department. If proper measurements are not given I understand it will delay the assignment of my 911 address.
2. I will provide one or more telephone number(s) at which I can be contacted, both daytime and evening:

Day: \_\_\_\_\_

Evening: \_\_\_\_\_

**IF YOUR SITE PLAN MEASUREMENTS IS NOT SUFFICIENT YOUR ADDRESS & CERTIFICATE OF OCCUPANCY WILL BE DELAYED.**

I UNDERSTAND THAT BY SIGNING THIS DOCUMENT I AM GRANTING PERMISSION FOR THE 911 ADDRESSING TECH TO MAKE A SITE VISIT ON MY PROPERTY IF NEEDED FOR THE PURPOSE OF 911 ADDRESS ASSIGNMENTS.

Request Submitted By:

\_\_\_\_\_  
*Signature*

\_\_\_\_\_  
*Date*

Your new 911 Address will be assigned based on measurements obtained from your site plan and will be available within three (3) business days from the receipt of the application and fee. The 911 Address is not issued to the individual, but to the dwelling being placed on this parcel, and may not be moved to another location.

SUWANNEE COUNTY BUILDING DEPARTMENT  
224 Pine Ave., Live Oak, FL 32064  
Phone 386-364-3407

**CONTRACTORS' ADDENDUM TO BUILDING PERMIT FOR MOBILE HOME**

Building Permit No. \_\_\_\_\_ Date: \_\_\_\_\_

Owner(s) Name: \_\_\_\_\_

Sec. \_\_\_\_\_ Twp. \_\_\_\_\_ Rge. \_\_\_\_\_ Tax Parcel #: \_\_\_\_\_

Lot #: \_\_\_\_\_ Block \_\_\_\_\_ Subdivision \_\_\_\_\_

I hereby certify that I will be commencing work on the above referenced job.

\_\_\_\_\_ **CONTRACTOR** \_\_\_\_\_ **LICENSE NO.** \_\_\_\_\_

ELECTRICAL: \_\_\_\_\_

\_\_\_\_\_  
Signature

MECHANICAL: \_\_\_\_\_

\_\_\_\_\_  
Signature

If the homeowner is performing the work above he/she must sign an owner builder disclosure along with this form.

**ALL SUBCONTRACTORS MUST SIGN FORM BEFORE PERMIT CAN BE ISSUED**



# DRIVEWAY APPLICATION

**SUWANNEE COUNTY PUBLIC WORKS DEPARTMENT  
13150 – 80<sup>TH</sup> TERRACE, LIVE OAK, FL 32064  
PHONE (386) 362-3992**

**FEE: \$50.00**

If your driveway access is off a State Roadway, please advise our office personnel. You will be required to contact Florida Department of Transportation for your driveway approval. (State Roads are as follows: 27, 51, 90, 129, 247, 49 SOUTH OF 27). **POWER WILL NOT BE RELEASE BY THE BUILDING DEPARTMENT UNTIL YOUR DRIVEWAY HAS BEEN APPROVED BY FDOT.**

## **DRIVEWAY REQUIREMENTS**

**POWER WILL NOT BE RELEASE BY THE BUILDING DEPARTMENT UNTIL YOUR DRIVEWAY HAS BEEN APPROVED BY THE COUNTY PUBLIC WORKS DEPARTMENT.**

When applying for a building permit, a form for the County Public Works Department must be completed for the Public Works Department to inspect your driveway to see what improvements must be made, if any. Please put stakes at the location of the proposed driveway entrance.

You must provide a printout showing the legal description of property and ownership from the property appraiser's office/website ([suwanneepa.com](http://suwanneepa.com)). If it shows in the name of the previous owner then you **MUST** (1) provide a copy of the recorded deed proving your ownership of the property, or (2) have a consent form signed by previous owner.

The Public Works Department will contact you as to the changes that must be made, if any. Please be sure to provide a current phone/fax number & email for them to contact you, otherwise there may be a delay.

It is your responsibility to make the improvements required by the Public Works Department and contact them directly (386-362-3992) to make a final inspection once improvements have been made.

After the Public Works Department has approved the entrance of your driveway, they will notify the Building Department.

SUWANNEE COUNTY PUBLIC WORKS DEPARTMENT  
13150 - 80TH TERRACE, LIVE OAK, FL 32064  
386/362-3992

Fax # \_\_\_\_\_

Permit # \_\_\_\_\_

**DRIVEWAY PERMIT APPLICATION**

FEE: \$50.00

IF YOUR DRIVE ACCESS COMES OFF ONE OF THE FOLLOWING STATE ROADS PLEASE ADVISE OFFICE PERSONNEL, IT WILL BE NECESSARY FOR YOU TO FILE AN APPLICATION WITH FLORIDA DEPARTMENT OF TRANSPORTATION – 27, 51, 90, 129, 247, 49 SOUTH OF 27

APPLICANT: \_\_\_\_\_ PHONE #: \_\_\_\_\_

CURRENT ADDRESS: \_\_\_\_\_

CONTACT EMAIL: \_\_\_\_\_ FAX #: \_\_\_\_\_

PROPERTY OWNER: NAME: \_\_\_\_\_

ADDRESS: \_\_\_\_\_

LEGAL DESCRIPTION:

Sec. \_\_\_\_\_ Twp. \_\_\_\_\_ S Range \_\_\_\_\_ E Tax Parcel No.: \_\_\_\_\_

Lot \_\_\_\_\_ Subdivision \_\_\_\_\_

Size \_\_\_\_\_ Acres Other Dwellings \_\_\_\_\_

**EXACT DRIVING DIRECTIONS FROM MAJOR ROAD LEAVING LIVE OAK TO SITE USING ROAD NUMBERS:**

Job Description \_\_\_\_\_ Use \_\_\_\_\_

Lot Frontage: \_\_\_\_\_ Ft. Number of Driveways: \_\_\_\_\_

**Application is hereby made to inspect a driveway(s) to access a "County Maintained Road" only.**

\_\_\_\_\_  
Date

\_\_\_\_\_  
Signature of Applicant

**To be completed by County Public Works Department**

Culvert Required: \_\_\_\_\_ Size: \_\_\_\_\_ "Corrugated Metal Culvert with Concrete Mitered Ends"

Apron Required: \_\_\_\_\_ Width: \_\_\_\_\_ "Concrete"

Limerock Required: \_\_\_\_\_ Level & Cap with **6 inches** of limerock, from edge of road to property line

Ditch Fill Required: \_\_\_\_\_ Width: \_\_\_\_\_ Depth: \_\_\_\_\_ Length: \_\_\_\_\_

Disapproved for the following reasons: \_\_\_\_\_

**APPLICANT MUST CALL PUBLIC WORKS DEPARTMENT at (386) 362-3992 FOR "REINSPECTION" AFTER COMPLETION OF THE ABOVE-MENTIONED REQUIRED MODIFICATIONS. DRIVEWAY MUST BE INSTALLED AND INSPECTED PRIOR TO OCCUPANCY OF STRUCTURE OR NOTIFICATION TO THE POWER COMPANY FOR ELECTRICAL SERVICE.**

Approved "As Is": \_\_\_\_\_

Final Approval (improvements completed): \_\_\_\_\_

\_\_\_\_\_  
Date

\_\_\_\_\_  
Supervisor of Driveway Inspection  
Suwannee County Public Works Department

# TYPICAL REQUIREMENTS FOR DRIVEWAYS NOT REQUIRING CULVERTS

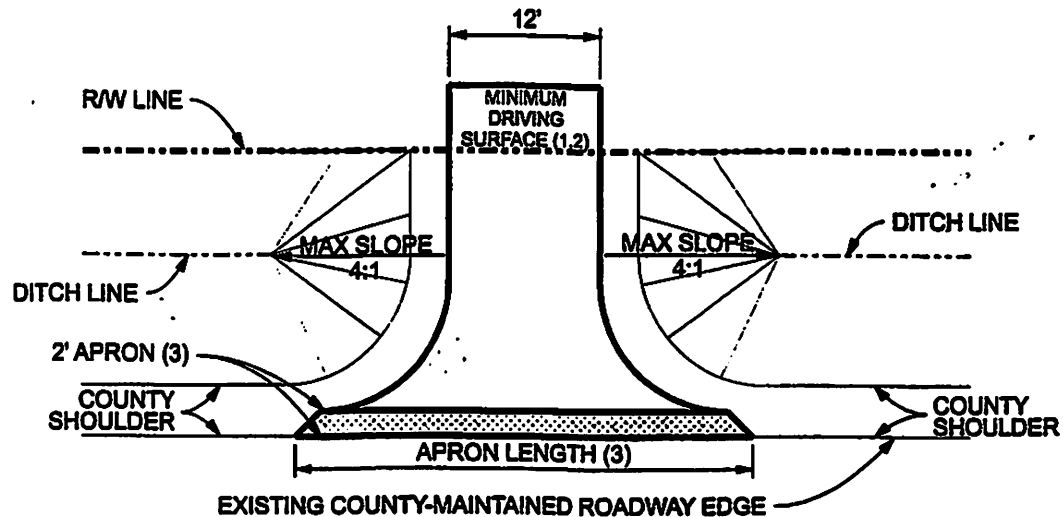

## PLAN VIEW

### NOTES:

1. DRIVEWAY SURFACE TO BE A MINIMUM WIDTH OF 12'
2. MINIMUM REQUIREMENTS FOR DRIVING SURFACE SHALL BE STABILIZED WITH 6" OF CRUSHED LIMEROCK (COMPACTED) OR OTHER APPROVED MATERIAL.
3. CONCRETE APRON REQUIRED ADJACENT TO PAVED ROADWAYS. APRON SHALL BE 2' WIDE AND 6" THICK. LENGTH TO BE DETERMINED BY PUBLIC WORKS DEPARTMENT
4. FILL AREA SIDE SLOPES SHALL NOT BE STEEPER THAN 4:1

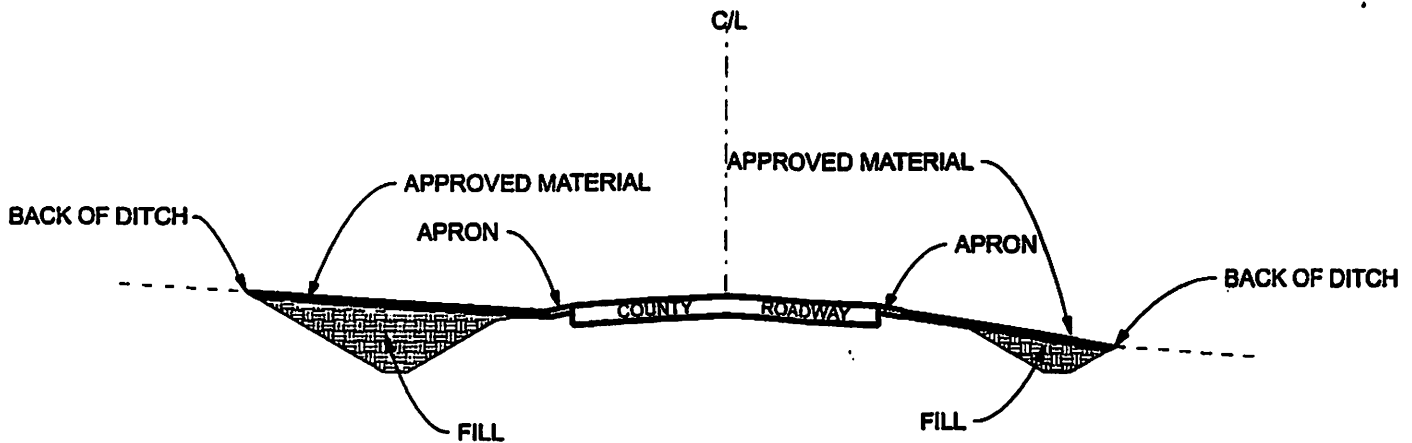

## SECTION VIEW

### NOTES:

1. TOP 6" OF FILL TO BE CRUSHED, COMPACTED LIMEROCK OR OTHER APPROVED MATERIAL
2. CONCRETE APRONS REQUIRED ADJACENT TO PAVED ROADWAYS, AND EACH IS TO BE 2' WIDE, 6" THICK AND LENGTH TO BE DETERMINED BY PUBLIC WORKS DEPARTMENT
3. DITCH FILL WIDTH WILL BE DETERMINED BY PUBLIC WORKS. FILL AREA SIDE SLOPES SHALL NOT BE STEEPER THAN 4:1.

# TYPICAL REQUIREMENTS FOR DRIVEWAYS REQUIRING CULVERTS

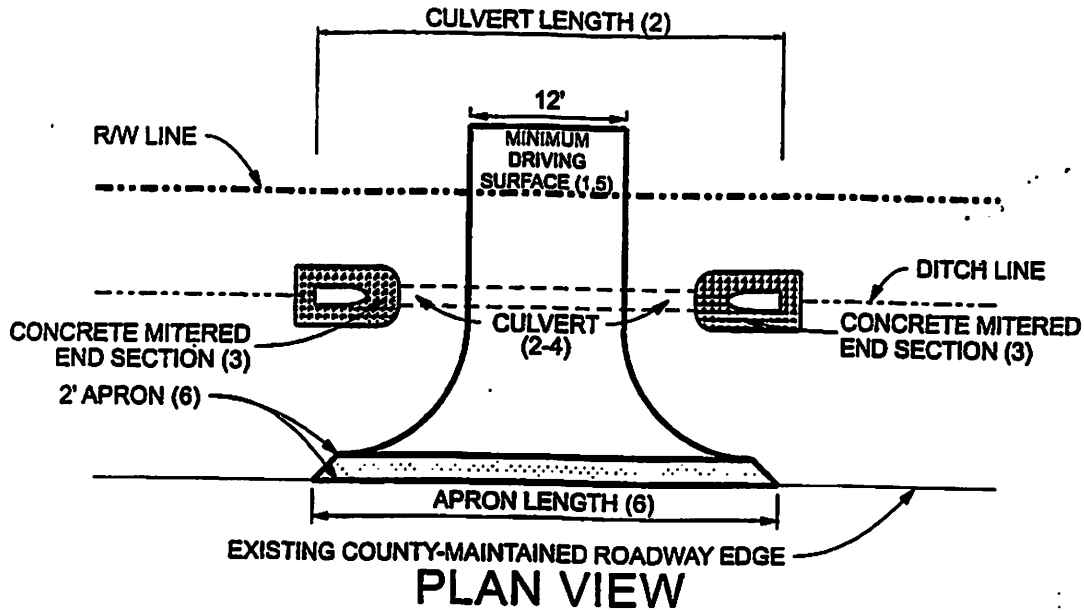

## NOTES:

1. DRIVEWAY SURFACE TO BE A MINIMUM WIDTH OF 12'
2. CULVERT LENGTH AND DIAMETER TO BE DETERMINED BY PUBLIC WORKS DEPARTMENT
3. CONCRETE ON MITERED ENDS (M.E.S.) SHALL BE CONSTRUCTED TO A MINIMUM OF 6" THICK AND MUST BE 2' IN WIDTH AROUND THE PERIMETER OF THE CULVERT OPENING - SEE ATTACHED M.E.S. DETAIL
4. MINIMUM COVER ON TOP OF CULVERT SHALL BE 6"
5. MINIMUM REQUIREMENTS FOR DRIVING SURFACE SHALL BE STABILIZED WITH 6" OF CRUSHED LIMEROCK (COMPACTED) OR OTHER APPROVED MATERIAL
6. CONCRETE APRON REQUIRED ADJACENT TO PAVED ROADWAYS. APRON SHALL BE 2' WIDE AND 6" THICK. LENGTH TO BE DETERMINED BY PUBLIC WORKS DEPARTMENT
7. FILL AREA SIDE SLOPES SHALL NOT BE STEEPER THAN 4:1
8. culvert must be corrugated metal.

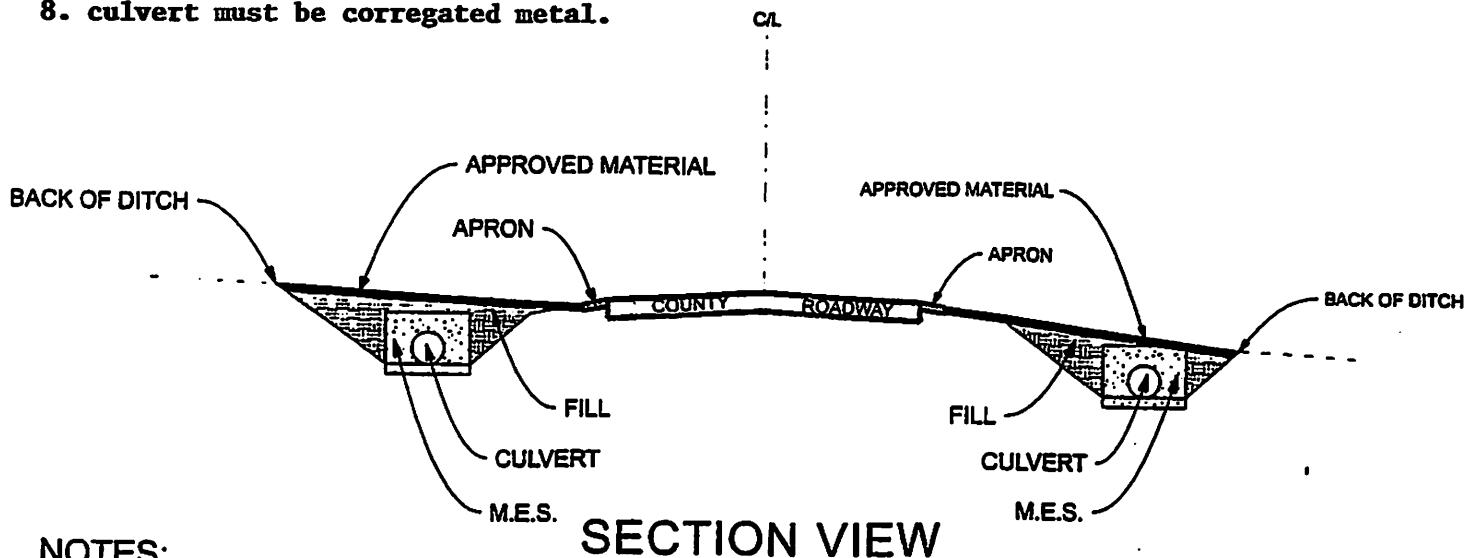

## NOTES:

1. TOP 6" OF FILL TO BE CRUSHED, COMPACTED LIMEROCK OR OTHER APPROVED MATERIAL
2. CONCRETE APRONS REQUIRED ADJACENT TO PAVED ROADWAYS, AND EACH IS TO BE 2' WIDE, 6" THICK AND LENGTH TO BE DETERMINED BY PUBLIC WORKS DEPARTMENT
3. DITCH FILL WIDTH WILL BE DETERMINED BY PUBLIC WORKS. FILL AREA SIDE SLOPES SHALL NOT BE STEEPER THAN 4:1.
4. MINIMUM COVER ON TOP OF CULVERT SHALL BE 6"

# TYPICAL REQUIREMENTS FOR MITERED END SECTIONS (MES)

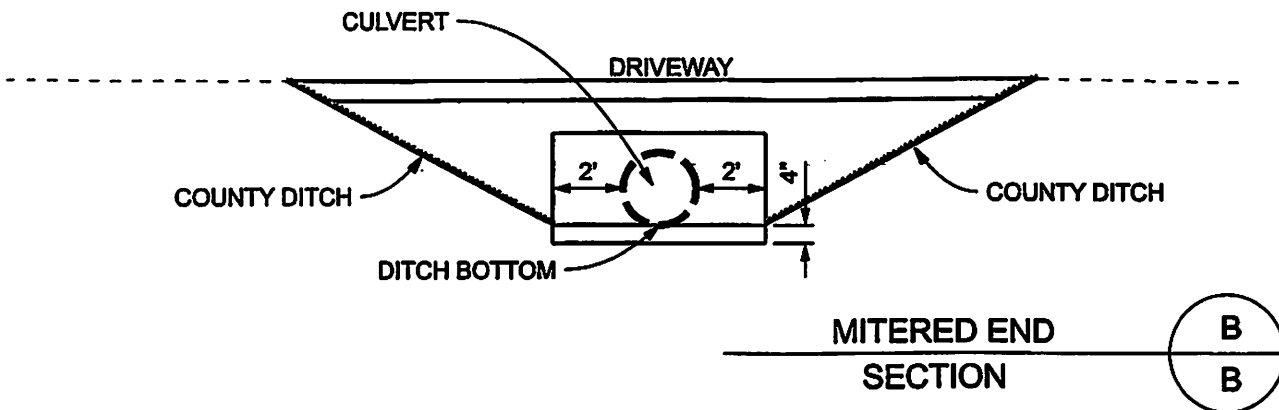
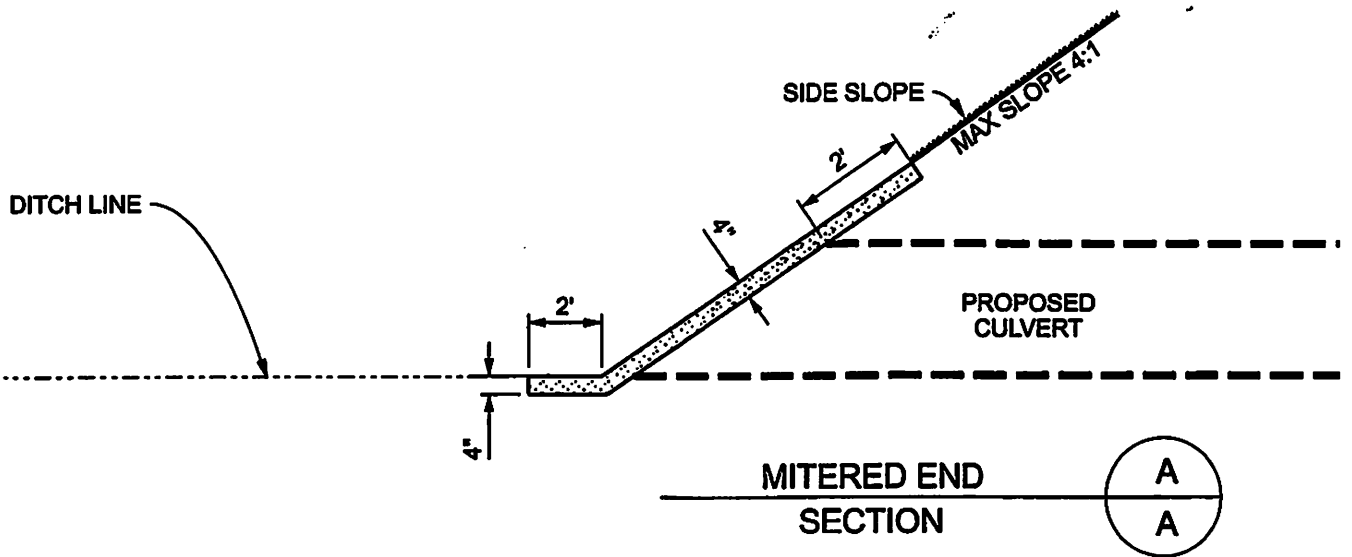
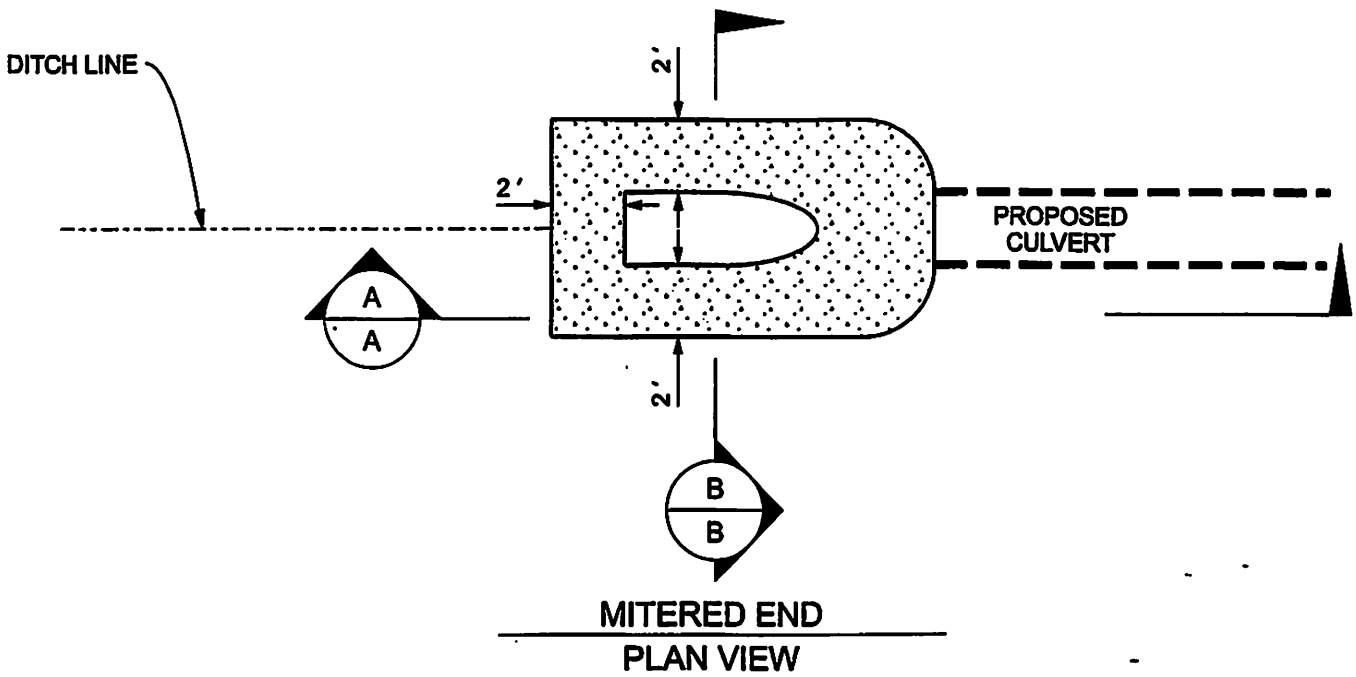

**SUWANNEE COUNTY BUILDING DEPARTMENT**  
**224 Pine Ave., Live Oak, FL 32064**  
**386-364-3407**

**Owner Builder Disclosure Statement for**  
**Property Address: \_\_\_\_\_**

(According to Florida Statute 489.103)

1. I understand that state law requires construction to be done by a licensed contractor and have applied for an owner-builder permit under an exemption from the law. The exemption specifies that I, as the owner of the property listed, may act as my own contractor with certain restrictions even though I do not have a license. Initials \_\_\_\_\_
2. I understand that building permits are not required to be signed by a property owner unless he or she is responsible for the construction and is not hiring a licensed contractor to assume responsibility. Initials \_\_\_\_\_
3. I understand that, as an owner-builder, I am the responsible party of record on a permit. I understand that I may protect myself from potential financial risk by hiring a licensed contractor and having the permit filed in his or her name instead of my own name. I also understand that a contractor is required by law to be licensed in Florida and to list his or her license numbers on permits and contracts. Initials \_\_\_\_\_
4. I understand that I may build or improve a one-family or two-family residence or a farm outbuilding. I may also build or improve a commercial building if the costs do not exceed \$75,000. The building or residence must be for my own use or occupancy. It may not be built or substantially improved for sale or lease. If a building or residence that I have built or substantially improved myself is sold or leased within 1 year after the construction is complete, the law will presume that I built or substantially improved it for sale or lease, which violates the exemption. Initials \_\_\_\_\_
5. I understand that, as the owner-builder, I must provide direct, onsite supervision of the construction. Initials \_\_\_\_\_
6. I understand that I may not hire an unlicensed person to act as my contractor or to supervise persons working on my building or residence. It is my responsibility to ensure that the persons whom I employ have the licenses required by law and by county or municipal ordinance. Initials \_\_\_\_\_
7. I understand that it is frequent practices of unlicensed persons to have the property owner obtain an owner-builder permit that erroneously implies that the property owner is providing his or her own labor and materials. I, as an owner-builder, may be held liable and subjected to serious financial risk for any injuries sustained by an unlicensed person or his or her employees while working on my property. My homeowner's insurance may not provide coverage for those injuries. I am willfully acting as an owner-builder and am aware of the limits of my insurance coverage for injuries to workers on my property. Initials \_\_\_\_\_
8. I understand that I may not delegate the responsibility for supervising work to a licensed contractor who is not licensed to perform the work being done. Any person working on my building who is not licensed must work under my direct supervision and must be employed by me, which means that I must comply with laws requiring the withholding of federal income tax and social security contributions under the Federal Insurance Contributions Act (FICA) and must provide workers' compensation for the employee. I understand that my failure to follow these laws may subject me to serious financial risk. Initials \_\_\_\_\_
9. I agree that, as the party legally and financially responsible for this proposed construction activity, I will abide by all applicable laws and requirements that govern owner-builders as well as employers. I also understand that the construction must comply with all applicable laws, ordinances, building codes, and zoning regulations. Initials \_\_\_\_\_
10. I understand that I may obtain more information regarding my obligations as an employer from the Internal Revenue Service, the United States Small Business Administration, the Florida Department of Financial Services, and the Florida Department of Revenue. I also understand that I may contact the Florida Construction Industry Licensing Board at (850) 487-1395 or [WWW.MYFLORIDA.COM/DBPR/PRO/CILB](http://WWW.MYFLORIDA.COM/DBPR/PRO/CILB) for more information about licensed contractors. Initials \_\_\_\_\_



**SUWANNEE COUNTY BUILDING DEPARTMENT**  
**224 Pine Ave., Live Oak, FL 32064**  
**386/364-3407**

**Owner Electrical Disclosure Statement for Permit # \_\_\_\_\_**  
(According to Florida Statute 489.503)

An owner of property making application for permit, supervising, and doing the work in connection with the construction, maintenance, repair, and alteration of and addition to a single-family or duplex residence for his or her own use and occupancy and not intended for sale or an owner of property when acting as his or her own electrical contractor and providing all material supervision himself or herself, when building or improving a farm outbuilding or a single-family or duplex residence on such property for the occupancy or use of such owner and not offered for sale or lease, or building or improving a commercial building with aggregate construction costs of under \$75,000 on such property for the occupancy or use of such owner and not offered for sale or lease. In an action brought under this subsection, proof of the sale or lease, or offering for sale or lease, of more than one such structure by the owner-builder within 1 year after completion of same is prima facie evidence that the construction was undertaken for purposes of sale or lease. This subsection does not exempt any person who is employed by such owner and who acts in the capacity of a contractor. For the purpose of this subsection, the term "owner of property" includes the owner of a mobile home situated on a leased lot. To qualify for exemption under this subsection, an owner shall personally appear and sign the building permit application and must satisfy local permitting agency requirements, if any, proving that the owner has a complete understanding of the owner's obligations under the law as specified in the disclosure statement in this section. If any person violates the requirements of this subsection, the local permitting agency shall withhold final approval, revoke the permit, or pursue any action or remedy for unlicensed activity against the owner and any person performing work that requires licensure under the permit issued.

State law requires electrical contracting to be done by licensed electrical contractors. You have applied for a permit under an exemption to that law. The exemption allows you, as the owner of your property, to act as your own electrical contractor even though you do not have a license. You may install electrical wiring for a farm outbuilding or a single-family or duplex residence. You may install electrical wiring in a commercial building the aggregate construction costs of which are under \$75,000. The home or building must be for your own use and occupancy. It may not be built for sale or lease. If you sell or lease more than one building you have wired yourself within 1 year after the construction is complete, the law will presume that you built it for sale or lease, which is a violation of this exemption. You may not hire an unlicensed person as your electrical contractor. Your construction shall be done according to building codes and zoning regulations. It is your responsibility to make sure that people employed by you have licenses required by state law and by county or municipal licensing ordinances.

**I have read and understand the terms of this disclosure statement and as an owner / builder I agree to abide by these terms.**

\_\_\_\_\_  
Owner Signature

\_\_\_\_\_  
Date



**SUWANNEE COUNTY BUILDING DEPARTMENT  
224 PINE AVENUE  
LIVE OAK, FL 32064  
PHONE: 386/364-3407**

Beginning December 08, 2023 a service charge was placed on all permits for habitable dwellings. This service charge represents a pro-rata portion of the Assessments based on the calendar year. This service charge is due, and **MUST** be paid before final power authorization can be released to the power company.

The rates (effective 12/08/2023) for the Urban and Rural Districts are as follows:

Month	Res. Fire Ass.	Solid Waste Ass.	Total
January	\$ 120.00	\$ 235.00	\$ 355.00
February	\$ 110.00	\$ 215.42	\$ 325.42
March	\$ 100.00	\$ 195.84	\$ 295.84
April	\$ 90.00	\$ 176.26	\$ 266.26
May	\$ 80.00	\$ 156.68	\$ 236.68
June	\$ 70.00	\$ 137.10	\$ 207.10
July	\$ 60.00	\$ 117.52	\$ 177.52
August	\$ 50.00	\$ 97.94	\$ 147.94
September	\$ 40.00	\$ 78.36	\$ 118.36
October	\$ 30.00	\$ 58.78	\$ 88.78
November	\$ 20.00	\$ 39.20	\$ 59.20
December	\$ 10.00	\$ 19.62	\$ 29.62

This service charge was enacted by the County on Dec. 4, 1990, by Resolutions 90-58, & 90-59 and is intended to help defray the costs of fire protection and solid waste services for the remainder of the year. The current fees are to be paid at the Building Department office. You (the property owner) will be billed for these services in all subsequent years in November when the property tax notices are sent out.

**Commercial Fire Assessment Fees** are .12 per square foot for 12-month period (decreases every month thereafter)

FORMS/SCFEE

## **DIRECTIONS TO THE SUWANNEE COUNTY COLLECTION SITES**

### **90 EAST**

90 EAST TO CR 49 – TURN LEFT ACROSS RR TRACKS-TURN BACK TO RIGHT

### **129 NORTH**

129 NORTH – NEAR INSPECTION STATION AND SPIRIT OF SUWANNEE

### **ANDERSON MINING**

49 – ½ MILE NORTH OF 27

### **BROWNWOOD (GOLDKIST)**

US 90 WEST TO GOLDKIST BOULEVARD – ON LEFT (BEHIND FARMERS CO-OP)

### **DOWLING PARK**

51 SOUTH TO CR 250 – JUST BEFORE 233<sup>RD</sup> ROAD ON RIGHT – 1 ½ MILE BEFORE RIVER

### **FALMOUTH**

90 WEST TO 185<sup>TH</sup> TURN LEFT TO 52<sup>ND</sup> STREET TURN RIGHT

### **FLETCHER**

INTERSECTION OF 49 AND 216<sup>TH</sup> STREET

### **HUMPHRIES**

129 SOUTH TO 216<sup>TH</sup> TURN LEFT 300 YARDS ON RIGHT

### **LANDFILL**

129 SOUTH TO 144<sup>TH</sup> STREET, TURN LEFT AT START OF LANDFILL ON LEFT

### **PEPPERS**

51 SOUTH (FROM TRAFFIC LIGHT AT 5 POINTS) APX 2 MILES ON RIGHT

### **REES**

136 EAST JUST PAST 80<sup>TH</sup> STREET ON LEFT – JUST BEFORE I-10

### **SPRAYFIELD**

HOUSTON TO NOBLES FERRY – WEST APPROXIMATELY 1 MILE ON RIGHT

### **TAYLOR**

51 SOUTH JUST BEFORE CR 252 ON LEFT

### **WELLBORN**

US 90 EAST TO CR 137 NORTH TO HOGAN ROAD

# Map Showing Locations of Each Site

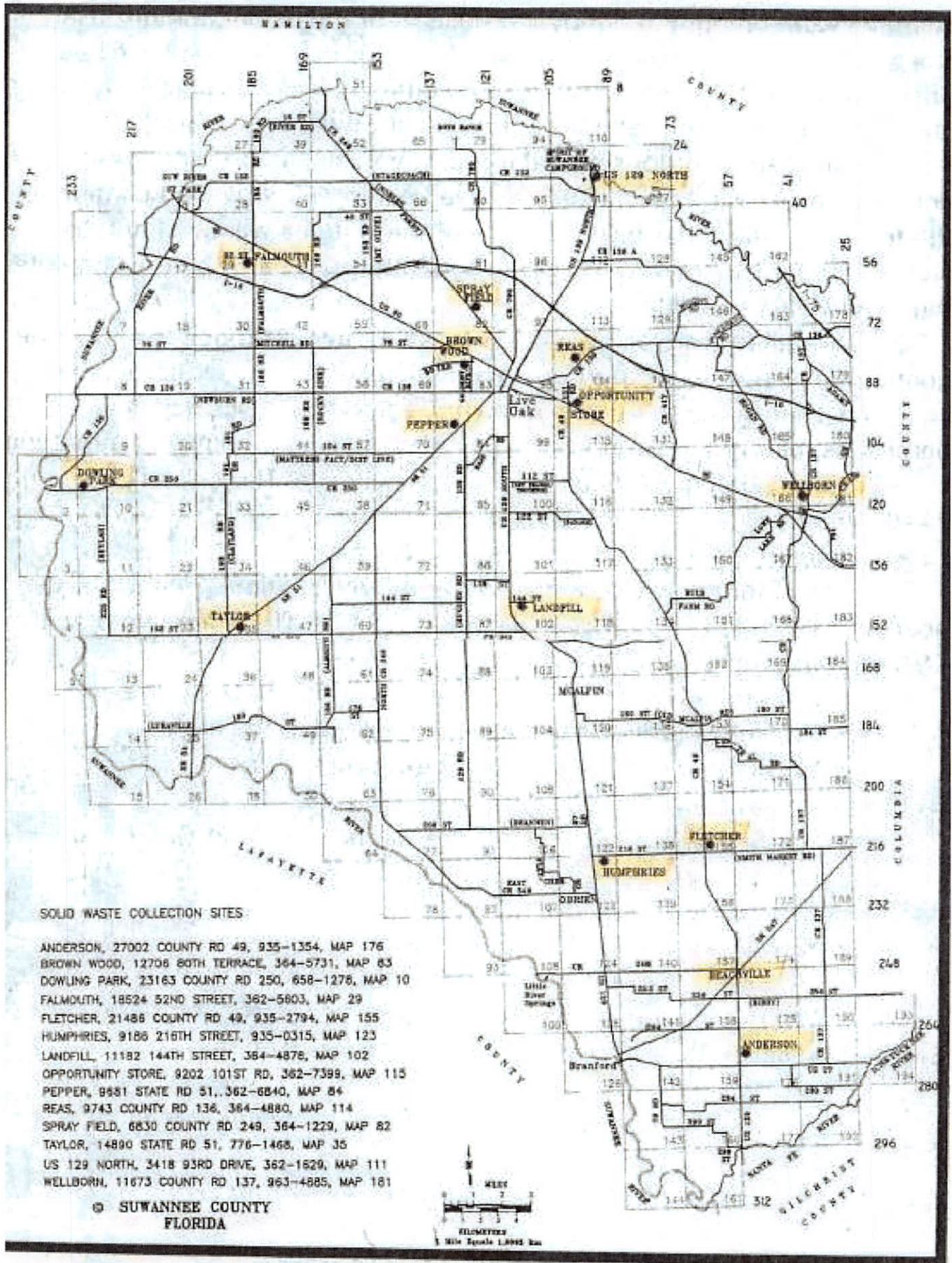

**SUWANNEE COUNTY COLLECTION SITE**  
**HOURS OF OPERATION**

(Effective July 10, 2017)

**OPEN**

**MONDAY – WEDNESDAY – FRIDAY - SATURDAY**  
**7:00 A.M. – 7:00 P.M.**

**CLOSED**

**TUESDAY – THURSDAY - SUNDAY**

**THE COUNTY LANDFILL LOCATED AT 10910 – 144<sup>TH</sup> STREET IS OPEN**  
**MONDAY – FRIDAY 8 AM – 4 PM**

**FOR MORE INFORMATION CALL (386) 208-3267**

**SUWANNEE COUNTY BUILDING DEPARTMENT  
HOW TO SET UP YOUR MOBILE HOME  
(TO MEET CODE REQUIREMENTS)**

**A. GENERAL REQUIREMENTS**

1. After septic installed call for Septic Final Inspection from County Environmental Health Department 386-339-6091.
2. Have potable (drinking) water supply piped to mobile home
4. Have electric power pole installed (see Paragraph "D" Electrical)
5. The heating and air conditioning unit must be installed at final inspection, if the unit is not installed before final inspection a separate permit and inspection is required.
6. Have letter of approval for driveway entrance from the County Road Department 386/362-3992. (Driveway permit applications available at Building Department)
7. 911 address must be posted at entrance of driveway, if more than 1 dwelling on property it must also be posted on each dwelling.
8. When above requirements are met and your mobile home is set up in accordance with Paragraphs "B", "C" and "D" below, call the Building Department for mobile home final inspection at 386/364-3407 between the hours of 8:00 a.m. and 4:30 p.m., Monday through Friday.
9. There will be a service charge for solid waste and fire protection charged on all permits for habitable dwellings. This service charge is due and **MUST** be paid before the Building Department can authorize electrical service to your dwelling; it is usually collected when mobile home permit is issued. Said fee is prorated therefore contact the Building Department for the exact fee.

**TWENTY-FOUR HOUR ADVANCED NOTICE REQUIRED FOR FINAL INSPECTION, HOWEVER  
THERE IS NOT GURANTEE OF NEXT DAY INSPECTION.**

**ALL OF THE ABOVE-MENTIONED REQUIREMENTS MUST BE MET AND INSPECTION PASSED  
BEFORE THE POWER COMPANY IS AUTHORIZED TO CONNECT ELECTRICITY TO YOUR  
MOBILE HOME.**

**NOTE: THERE WILL BE A \$35.00 REINSPECTION FEE CHARGED IF SCHEDULED INSPECTION  
IS NOT READY AT THE REQUESTED TIME. SUBSEQUENT REINPSECTION FEES WILL BE  
\$50.00 FOR ADDITIONAL INSPECTIONS.**

**B. ANCHORING AND BLOCKING:** (Administrative Rules 15C-1 and 15C-2)

This form shall be completed by the Mobile Home Installer and will become a part of the permit. **Note:** Vapor Barriers 6 mil required and site prep may be required.

**NOTE: ALL ANCHOR SHACKLES MUST BE INSTALLED AT GROUND LEVEL.**

**C. PLUMBING**

1. Water supply pipes must be at least  $\frac{3}{4}$  inches and may be Schedule 40 PVC or copper pipe and buried at least 12 inches deep in the soil.
2. Just below the point of entry into mobile home a cutoff valve and hose connection faucet with back flow prevention **must** be installed. Hose connection faucet should be **below** cutoff to retain water pressure on hose after valve is shut off.
3. 4 inch PVC into tank and main drain (sewer) lines must be at least 3 inch Schedule 40 PVC (white) or Schedule 40 ABS (black) but **DO NOT INTERMIX** the two kinds of pipe and fittings.
4. A full diameter clean-out must be installed for each 50 feet of main drain pipe or at all 90-degree bends. Clean-outs must be installed with flow in direction of septic tank.
5. A clean-out is required within 3 feet from mobile home.

**D. ELECTRICAL SERVICE**

1. **ALL** electrical equipment and wiring **MUST** conform to the National Electrical Code requirements.
2. **ALL** electric conductors (wire/cable) above-ground use must be in Schedule 80 a depth of at least 18 inches below ground to 8 feet above ground. All electrical placed under mobile home must be in conduit and secured to frame of mobile home.
3. If buried wires are not in conduit (direct burial), they must be type **UF** or **USE**, and buried not less than 24 inches deep. (When running water line in same ditch as electrical line, install water line 6 inches minimum above electrical line on mound spaced every 10 feet apart, and leave ditch open for inspection.
4. **If buried in water-tight conduit**, almost any type electrical wire of approved size may be used and must be buried not less than 18 inches deep. (Leave ditch open for inspection. All joints and connections must be water tight.
5. The power pole must conform to all requirements in the drawing attached and set not less than three (3) feet or more than 30 feet from mobile home. Main circuit breaker and wire size from mobile home to the pole disconnect panel must match amperage rating marked on metal tag outside of your mobile home or the inside load center main breaker, whichever is greater. Service to older homes without tag must match main circuit breaker inside mobile home.

6. Grounding of the power pole must be made by attaching a No. 4 continuous copper wire from the neutral grounding lug in the meter base and is clamped to two 8 foot approved ground rods at least 6' apart. These rods must be driven to 1 foot below ground level and left exposed for inspection. You must use approved Acorn type ground rod clamps.
7. The fourth wire from the power pole to the mobile home is very important because it is the bonding circuit. It must be a stranded No. 4 wire, and must be insulated. Older homes may not be equipped for fourth bonding bar, however, you must add a bonding bar, and must be grounded from the frame.
8. Circuit breakers and wire providing electrical service to pumps and air conditioners from the power pole must be matched as follows:
  - a. No. 12 wire on not more than 20A circuit breaker
  - b. No. 10 wire on not more than 30A circuit breaker.
9. If an air conditioner compressor unit is installed outside the mobile home, the following applies:
  - a. Circuit breaker must not exceed maximum amperage as stated on label attached to air conditioning unit.
  - b. A separate disconnect must be installed at the air conditioning unit if not within sight and readily accessible from the outside load center.
  - c. Unit must be set on a foundation which will support the load and keep it above 3" ground clearance.

#### **E. FUTURE CONNECTIONS**

1. **FAILURE TO OBTAIN BUILDING PERMITS FOR FUTURE CONNECTION, ADDITIONS OR MAJOR IMPROVEMENTS MAY RESULT IN PROSECUTION (MISDEMEANOR) AND A FINE OF UP TO \$500.00 PER DAY.**